

tioned two openings of the lower piping, a feed pump for a sample and a feed pipe for pressurized air, and a lift for moving the upper frame up and down, the apparatus being designed in such a manner that either one or two of a fluidizing chamber, a filter chamber, and a spray drying chamber can be connected between one opening of the lower piping and the corresponding opening of the upper piping, and the other openings of the upper and lower pipings can be provided with one or more of a heater, an aspirator, and a cyclone.

4358310

DRY COLLECTION OF METALLIZED FINES

Charles W Sanzenbacher; David C Meissner assigned to Midrex Corporation

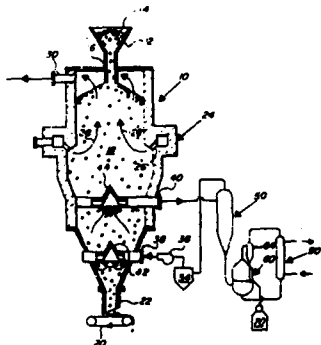

A method and apparatus for the dry collection of metallized fines from a direct reduction furnace cooling zone in which cooling gas removed from the cooling zone passes through a dust collector and the removed dust is cooled in a fluidized bed, the fluidizing gas being recirculated through an indirect cooler. The process is continuous and the fines are collected at a sufficiently low temperature for easy handling. The apparatus includes a hot gas cyclone in the cooling gas withdrawal line connected to a fluidized bed cooler, a conduit for withdrawing fluidizing gas from the fluidized bed cooler passes through a second cyclone dust collector then through an indirect cooler and returns to the fluidized bed cooler. Cool fines are withdrawn from the fluidized bed cooler into a collector.

4357907

FLUIDIZED BED COMBUSTOR WITH IMPROVED INDIRECT HEAT EXCHANGER UNITS

John Campbell; Larry H Russell; Philip I Robinson assigned to Rockwell International Corporation

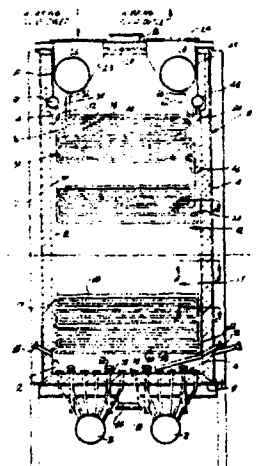

There is provided a fluidized bed combustor comprising an economizer contained in an upper interior portion and indirect heat exchange conduits suspended in the lower interior portion of the fluidized bed combustor in spaced relation to the interior surfaces of the fluidized bed combustor.

4357883

BED DRAIN COVER ASSEMBLY FOR A FLUIDIZED BED

Joseph R Compareate; Martin Jacobs assigned to Combustion Engineering Inc

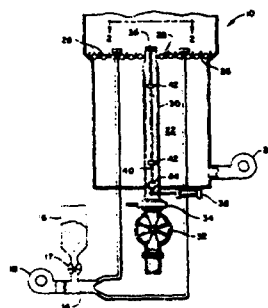

A loose fitting movable cover plate (36), suitable for the severe service encountered in a fluidized bed combustor (10), restricts the flow of solids into the combustor drain lines (30) during shutdown of the bed. This cover makes it possible to empty spent solids from the bed drain lines which would otherwise plug the piping between the drain and the downstream metering device. This enables use of multiple drain lines each with a separate metering device for the control of solids flow rate.

4356779

FLUIDIZED BED SOLIDS FEED

James H Porter; Robert Davis; Jehangi Zakaria assigned to Energy Resources Company Inc

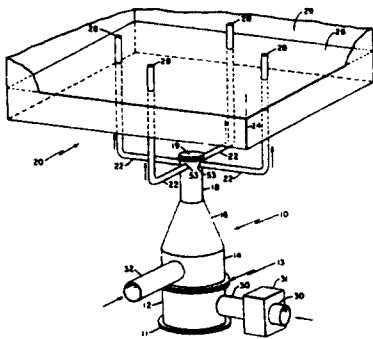

A fluidized-bed system for feeding coal or a coal-limestone mixture into a fluidized bed combustor, a perforated horizontal distributor plate dividing the chamber into upper and lower chamber sections, means for feeding solid fuel particles into the upper chamber section, a source of high velocity gas connected to the lower chamber section and passing through the plate into the upper chamber section for entraining the particles, means for heating the high velocity gas before it is introduced into the upper chamber, an entrainment section defined by converging upper sides of said fuel feeding chamber, and a stream splitting section disposed above said entrainment section and connected to a plurality of pneumatic transport lines each penetrating the distributor plate of a fluidized bed combustor and terminating in an outlet feedport.

4355601

RECIRCULATING FLUE GAS FLUIDIZED BED HEATER

Uday S Hattiangadi assigned to Conoco Inc

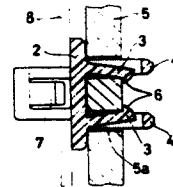

A fluidized bed boiler system and a manner of operating the same is provided wherein a fluidized particulate bed in which solids are not recycled is utilized. High temperature flue gas is directed to a boiler means. A portion of both the high temperature and a low temperature gas stream are recycled to a fluidizing gas stream for fluidizing the particulate bed.

4354903

PROCESS FOR DRYING AND PREHEATING COAL UTILIZING HEAT IN DRY COOLING OR QUENCHING OF COKE

Heinric Weber; Kurt Lorenz; Horst Dungs assigned to Firma Carl Still GmbH & Co KG

A three-cycle process as disclosed for drying and preheating coking coal using the

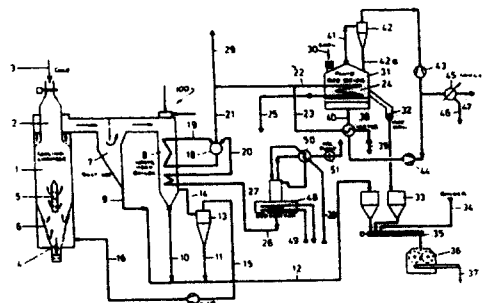

heat from cooled coke. Cooling gas is passed over hot coke to heat the cooling gas and cool the coke. The heated cooling gas is then passed through a waste heat